



# SilverShine CDM 6k

## COMMERCIAL CUTLERY DRYER/POLISHER SANITIZER



### Product Description:

The SilverShine™ CDM cutlery dryer performs several functions under its stainless-steel skin. Primarily to be used to eliminate the labor-intensive task of drying flatware (stainless, silver plate, sterling) the SilverShine™ will retain cutlery's original shine, or over extended use can restore a shine to older cutlery. Using a UV-C germicidal lamp combined with heat, the SilverShine™ also ensures a more complete removal of bacteria which might otherwise survive the dishwashing process.

The SilverShine™ is compact and mobile enabling it to move about anywhere in the facility to where it is either needed most, or where it seamlessly blends into the kitchen procedure. With simple "plug and play" ability the machine is ready to begin work right away. This unit can process up to 12,000 pieces of cutlery per hour.

### Performance Features:

- Long life calrod resistance point for higher operating temperatures
- Resistance point temperatures as high as 338°F for maximum sanitizing effect
- Germicidal lamp operating output of 253.7nm to eradicate bacteria
- Constant average operating temperature in NAUTILUS tub of
- 150°F -170°F for continuous sanitizing effect
- Easy to open service/fuse panel
- Granulate good for up to 400 hours of operation
- Simple one button operation with safety shut-off
- Quiet, vibration free

### Construction Features:

- Stainless steel construction throughout
- Heavy-duty Stainless-Steel exterior with polished finish to withstand tough kitchen environments
- Patented wide-mouth intake hopper for easy loading
- Solid steel frame on constructed sub frame for years of use
- Patented INOX stainless steel NAUTILUS tub to withstand heat
- Powder-coated steel vibration grid
- Powerful ½ HP electric motor with efficient low amp. draw
- Protected UVC Germicidal lamp with automatic cut-off
- Tough ¼ inch thick plastic discharge chute
- Moisture resistant heavy duty steel springs (4) to transfer energy to frame
- Standard four (4) heavy duty castors, two (2) locking for maximum mobility

### Included Accessories:

- Custom bus bin with perforated insert
- Initial batch of vacuum sealed, dust-free vegetable granulates (20lb tub)
- Operations/maintenance manual

### Replacement Items:

- Vacuum-sealed, dust-free vegetable granulate 20lb tubs (require replacing approx. 3X/year)
- Additional UV-C Lamps
- Additional custom bus bins with perforated inserts



### Campus Products Inc

2871 Brighton Road, Oakville, Ontario L6H 6C9

Tel: 1.866.912.3469 Website: [www.cpushine.com](http://www.cpushine.com)





# SilverShine CDM 6k

COMMERCIAL CUTLERY DRYER/POLISHER SANITIZER

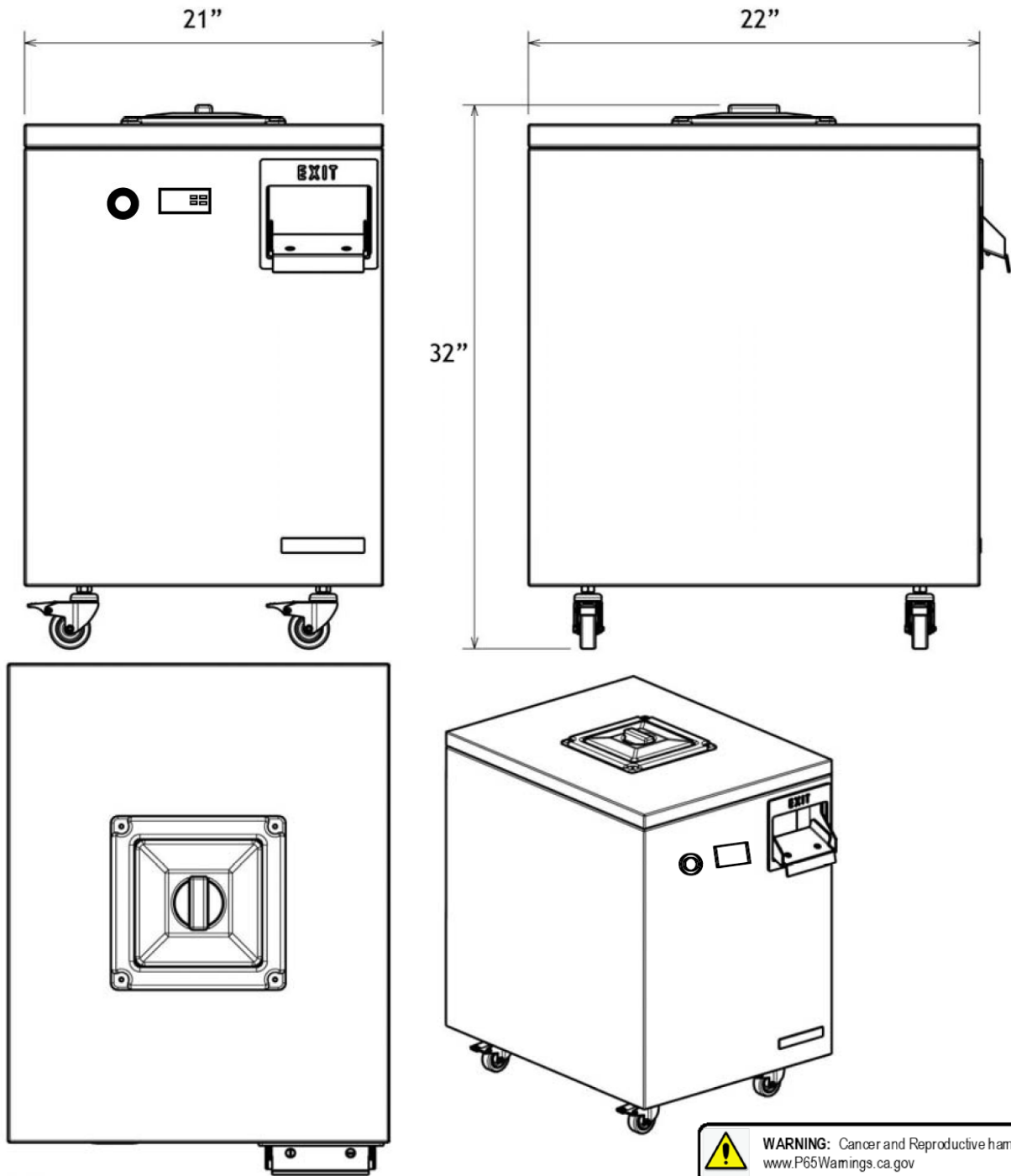

 **WARNING:** Cancer and Reproductive harm —  
[www.P65Warnings.ca.gov](http://www.P65Warnings.ca.gov)



### Specifications:

Amps:	5.80	Shipping Weight:	232 lbs.
Watts:	1200	Capacity:	6,000 Pieces /hr
Dimensions (W x D x H):	21" x 22" x 32"		
Volts:	120		



### Campus Products Inc

2871 Brighton Road, Oakville, Ontario L6H 6C9  
 Tel: 1.866.912.3469 Website: [www.cpishine.com](http://www.cpishine.com)

